

Non Load bearing GRP Floor

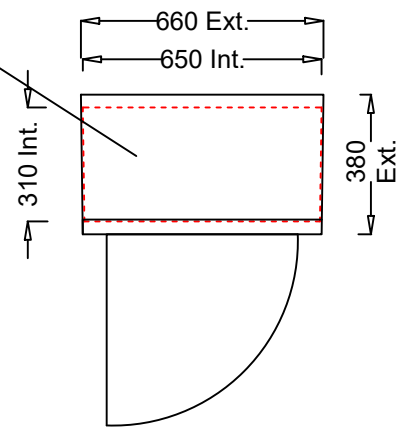

1No. 460 x 1000 mm, 18mm Surface Treated Ply Backboard

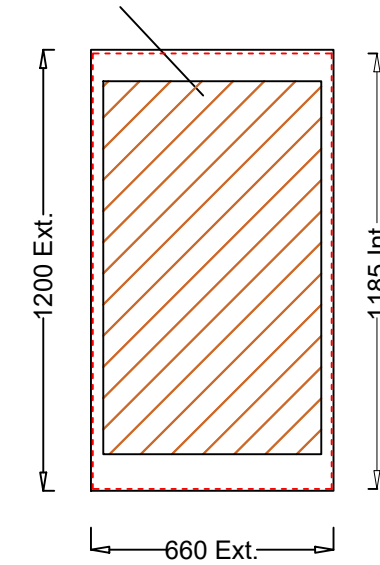

1No. Single door (520 mm W x 1020mm H Clear Opening)  
 2No. St/St Hinges  
 1No. Yale type Lock  
 1No. Compression Seal

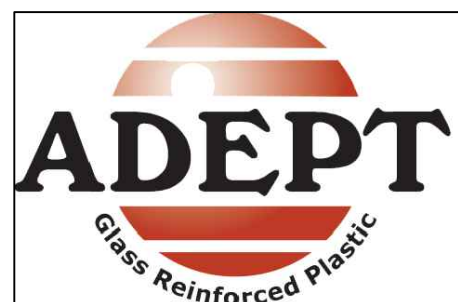
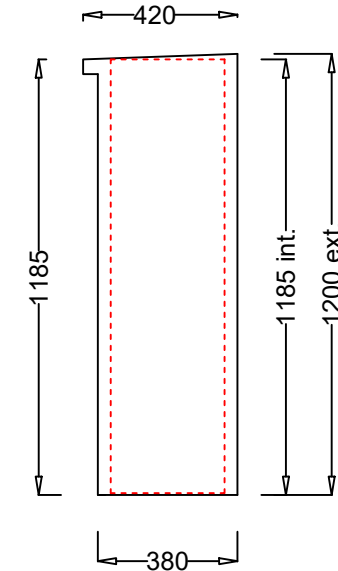
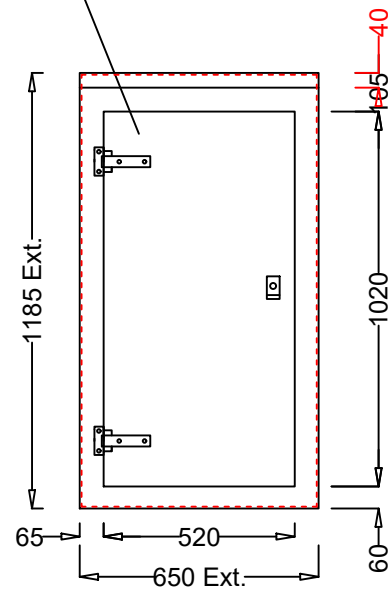
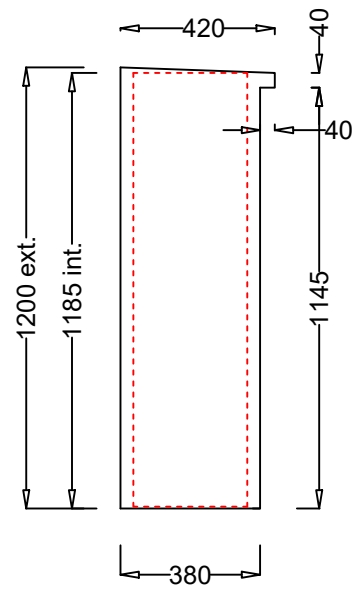

Adept GRP Cabinets Ltd  
 Tel: 01269 843355  
 Tel: 01269 832189  
 Fax: 01269 844324  
 Unit 4, Heathfield Industrial Estate,  
 Thornhill Rd, Cwmgwili, Crosshands  
 SA14 6PT

Company: ADEPT GRP Cabinets Ltd

Contact: Daniel Phillips

Scheme Title: VN2

Drawn:Liam Brown

Date: 21.08.23

Approx. Weight = 30KG

External Colour - BS 14-C-39 or BS 10-A-05

"U" Value = 3.0 W/sq.m/degC

Construction: Single skin

Rev: A